

Barkhausen – OFP-metod i industrin

Presentation FOP's vårkonferens 2024



Per Lundin

Lundin Stress Service AB

April 2024

Bakgrund



Per Lundin
Civ.Ing. Teknisk Fysik, Materialfysik
Mer än 25 års erfarenhet inom material och restspänningar



Erbjudande



Forskning



Utbildning



[©RISE AB]

Mätservice



Service & underhåll



Restspänningar, mätmetoder

Förstörande metoder

- Kontur
- Hålbörning, konventionell alt. ESPI
- Röntgendiffraktion (djupprofil)

Oförstörande metoder

- Röntgendiffraktion (på ytan)
- Synkrotrondiffraktion *
- Neutrondiffraktion *
- Barkhausen
- Ultraljud

Barkhausenbrus

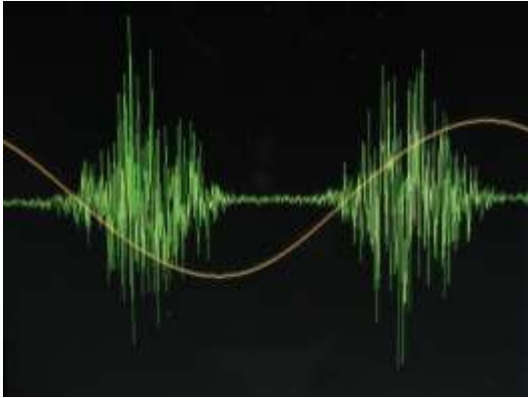

En elektromagnetisk signal som genereras i ett ferromagnetiskt material av ett externt magnetiskt fält.

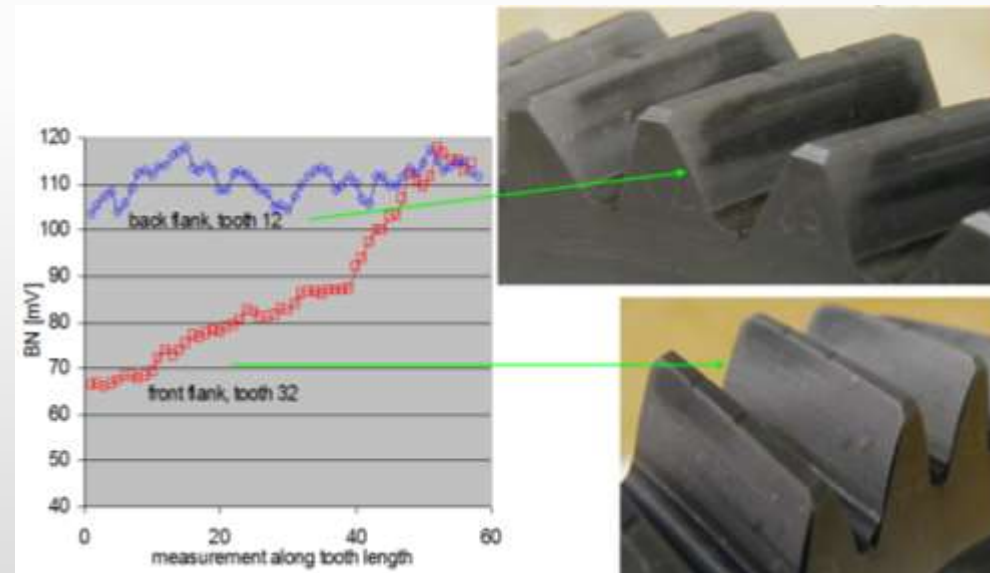

[©Stresstech Oy]

Barkhausenbrus

- Snabb och säker metod
- Används främst för optimering av **slipning** och **värmebehandling**
- Kan automatiseras
- Påverkas av **restspänningar** och **hårdhet**



[©Stresstech Oy]

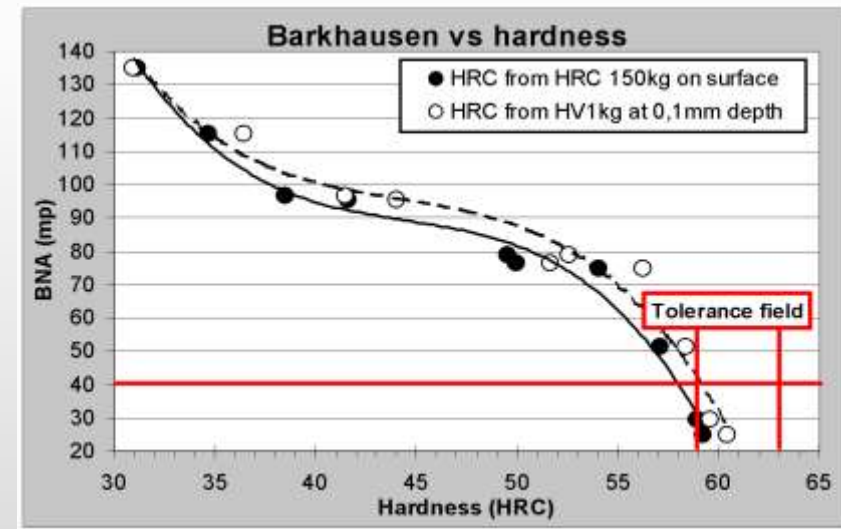

[©Scania CV AB]

Bilindustrin, kamaxlar



[©Stresstech Oy]



[©Scania CV AB]



[©Stresstech Oy]



Bilustrin, kamaxlar



[©Stresstech Oy]

**Stress
Service**

Bilindustrin, vevaxlar



[©Stresstech Oy]

Bilindustrin, kuggghjul

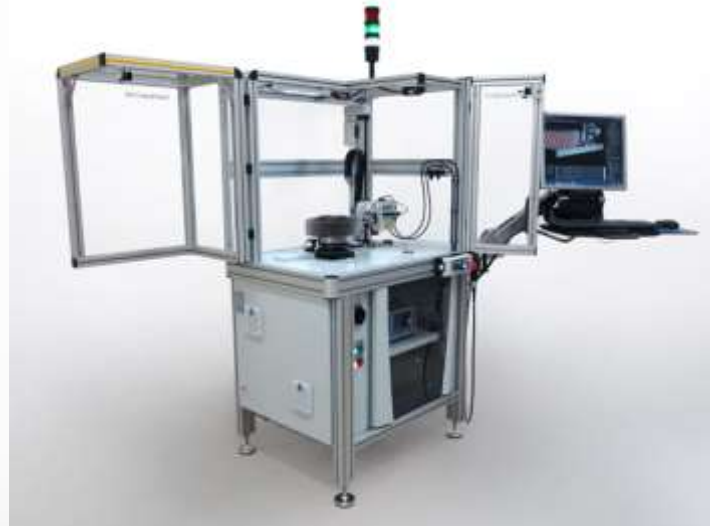

[©Stresstech Oy]

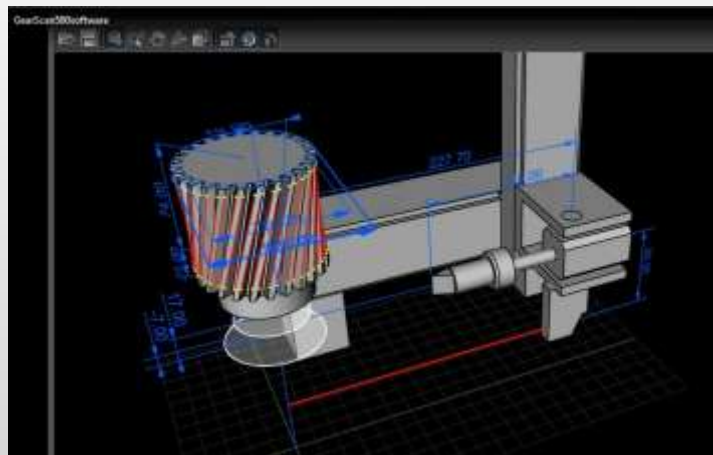

Bilindustrin, kuggmätmaskin

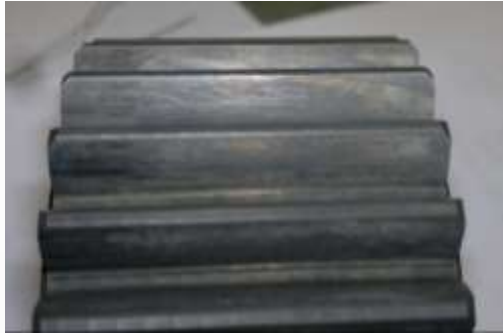

[©Stresstech Oy]



Bilindustrin, kronhjul & pinjong



[©Stresstech Oy]

Bilindustrin, ventillyftararmar



[©Stresstech Oy]



Verkstadsindustrin, kuggghjul

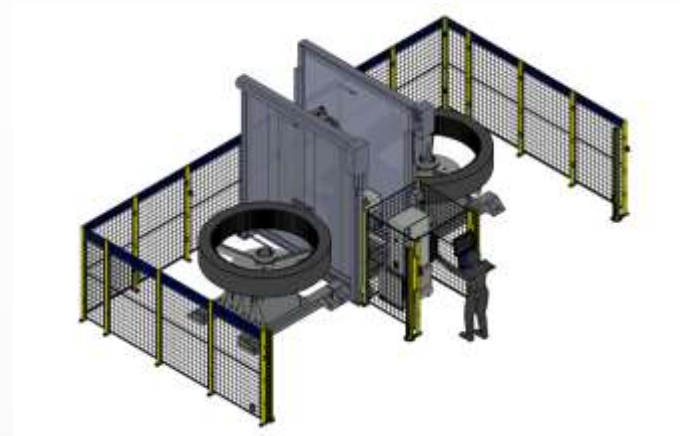

[©Stresstech Oy]

Verkstadsindustrin, hydraulmotorer



[©Stresstech Oy]



Verkstadsindustrin, motorsågar



[©Husqvarna Group AB]

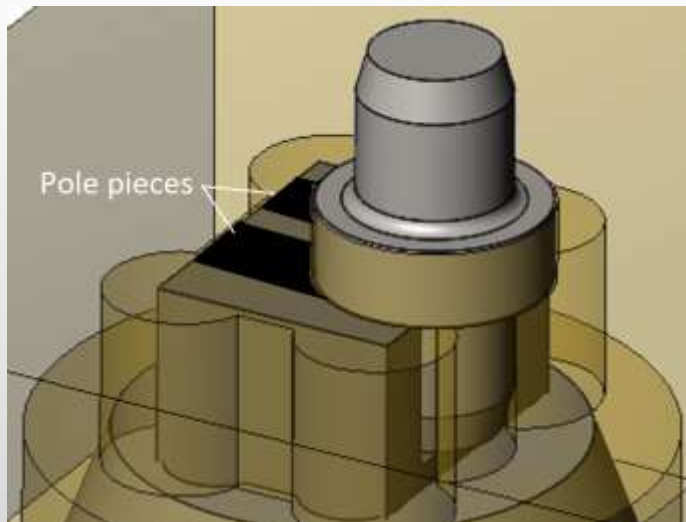

[©Stresstech Oy]

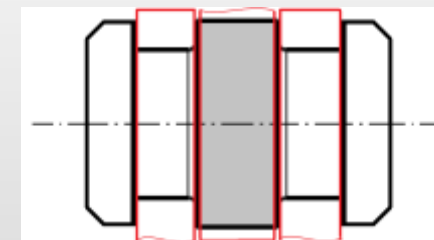
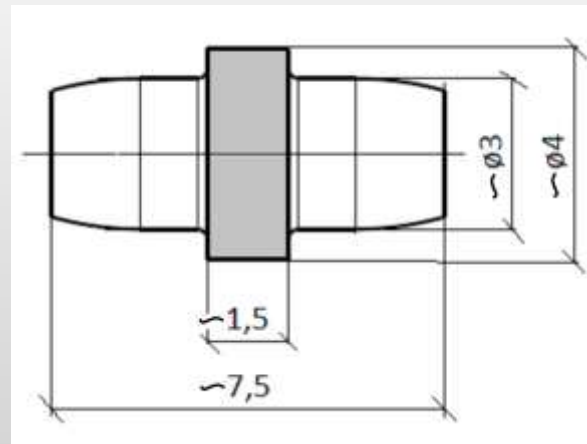

Barkhausenbrus, industrireferenser (SE, DK)

Aurobay

BoschRexroth

Danfoss Power Solutions

GKN Driveline

Gnutti Carlo

Parker Hannifin

Scania CV

SKF MD

SwePart Transmission

Volvo Construction Equipment

Volvo Powertrain

Volvo Powertrain

Skövde

Mellansel

Nordborg, DK

Köping

Kungsör

Trollhättan

Södertälje

Göteborg

Liatorp

Eskilstuna

Köping

Skövde

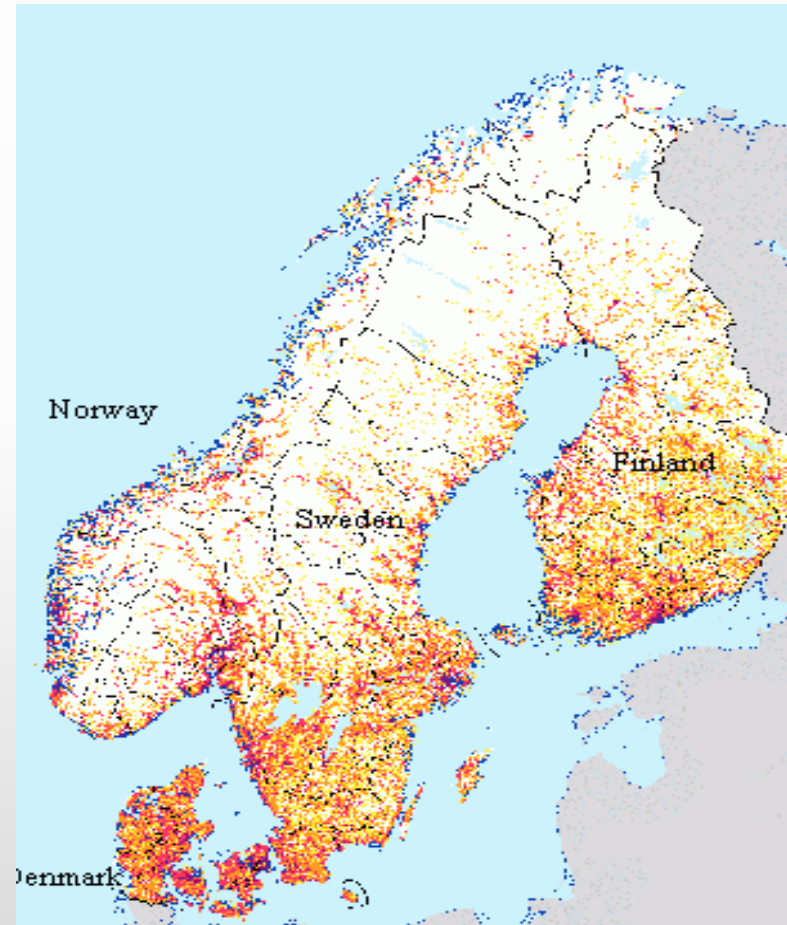

Barkhausenbrus, videos

Barkhausen noise automation videos

Robotized Grinding Burn Detection:

<https://www.youtube.com/watch?v=YOZ1TzJG5Qg>

GearScan 500 - Barkhausen Noise Analysis for Gear Inspection:

<https://www.youtube.com/watch?v=aKHR4m2-PHA>

Aktuellt

ICBM15, 15th International Conference on Barkhausen noise and Micromagnetic Testing, Tampere Finland, 23-26 September 2024

LUS4Metals 2024, 6th International Workshop on Laser-Ultrasound for Metals, Swerim Kista, 22-23 Maj 2024

UTREST, Non-destructive ultrasonic measurement of residual stress in metallic materials, Okt 2022-Dec 2024. Birefringence (dubbelbrytning) effekt, vinkelrätt polariserade skjuvvågor för att möta restspänningar i valsad grov stålplåt



[©www.tuni.fi]



[©www.swerim.se]



Now, relieve your stresses and relax

Per Lundin
Lundin Stress Service AB

Tel. +46 (0)70 638 60 48
E-mail per.lundin@stress-service.se
Web www.stress-service.se

**Stress
Service**